

EM9928 125KHz DESKTOP CARD READER

APPLICATION

EM9928 is a GK4001 Reader unit that reads code from GoldKey GK4001(read only) and H4100,H4102 tags which is a major component in an RFID (Radio Frequency Identification) Reader system. It can be deployed in application such as office/home security, personal identification, animal trans-ponder, anti-forgery, interactive toy and production control systems.

GENERAL FEATURES

- 125KHz carrier frequency
- Reading of Amplitude modulated transponders
- Efficient tag management
- Easy to build up a control system

BRIEF INTRODUCTION

1.SYSTEM COMPOSE

- An GK4001 Reader unit
- Include A 10-cm diameter square antenna coil
- GOLDKEY GK4001 or GK4011 tags

Following diagram shows main connections of the different parts:

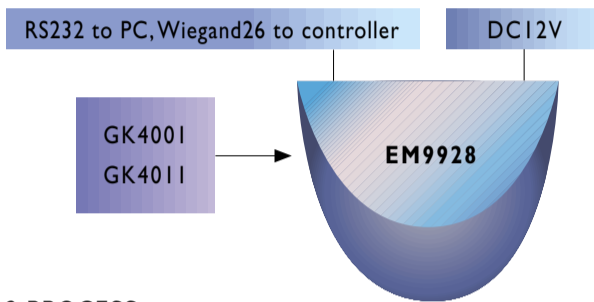

2.PROCESS

This reader is supplied in a PCB board containing RF circuits, an 8-bit microcontroller and data output connections. Its main functions are driving the antenna, sending demodulated data into microcontroller, checking the input data code and processing the output data format. A 18 Pin microcontroller is used to convert input pulse signals to Manchester code, check the input data code and process the output data format.

3.SYSTEM FUNCTION

Hardware function • Using the GOLDKEY GK4001 64bit Manchester code fixed-code tag, the transceiver can read the GK4001 tag code in 10~15 cm distance not more than 70 ms under 125KHz frequency.

Software function • Decode Manchester code

- Check input data format
- Re-organize database in microcon-troller
- Format output code.Show output data ready

4.EXTERIOR CONNECTION

Power Supply An external DC 12V voltage that provides 0.2A current power supply is needed. For current limitation.

Tags GOLDKEY GK4001 tags and GK4011 tags can be applied to the system. For their IC specifications, please refer to the document of GOLDKEY GK4001 and GK4011 data sheet.

Data Link

① GK4001 data code format

ROW0	D03	D02	D01	D00	PR0
ROW1	D13	D12	D11	D10	PR1
ROW2	D23	D22	D21	D20	PR2
ROW3	D33	D32	D31	D30	PR3
ROW4	D43	D42	D41	D40	PR4
ROW5	D53	D52	D51	D50	PR5
ROW6	D63	D62	D61	D60	PR6
ROW7	D73	D72	D71	D70	PR7
ROW8	D83	D82	D81	D80	PR8
ROW9	D93	D92	D91	D90	PR9
PC3	PC2	PC1	PC0	0	

- The header format is 9 digits of '1' for reader to identify. D00~D93 are data bits for user
- PR bits are the row parity check bits(even parity). For example: When D00~D03 are 0101, PR0 is 0.
- PC bits are the column parity check bits that are also even parity

② RS232 interface format

This IFD4001 transceiver unit is designed as RS232-ready. Please follow these notes:

- The connection of RS232 interface is ready in the PCB schematic, please refer to the instruction to connect.
- Interface of a computer that accepts the RS232

data can use the Windows application software "Hyper Terminal" which defines the COM port and sets these data:

- 1.Data baud rate: 9600
- 2.Parity check : NONE
- 3.Stop bit : 1
- 4.Flow control : HARDWARE.

• RS232 interface software is programmed in the IFD4001 microcontroller which can transfer the 40 bits data (i.e., 64 bits excluding a bit header and 15 bit parity) into a 10 digits ASCII code.

For example:

The data code output from the tag is:

B0---,B9---, B14---, B19---, B24---, B29---, B34---, B39---, B44---, B49---, B54---, B59---, B63
 11111111,10001,01001,11000,00101,10100,01100,
 11101,00011,10010,01010,11010

Weigand26 data format:

BIT	0	1	2	3	4	5	6	7	8	9	10	11	12	13	14	15	16	17	18	19	20	21	22	23	24	25
Note	P	D	D	D	D	D	D	D	D	D	D	D	D	D	D	D	D	D	D	D	D	D	D	D	D	P
	P	E	E	E	E	E	E	E	E	E	E	E	E	E	E	E	E	E	E	E	E	E	E	E	E	P
		O	O	O	O	O	O	O	O	O	O	O	O	O	O	O	O	O	O	O	O	O	O	O	O	P

Note:

E: Summed for even parity O: Summed for odd parity
 D: Data code for card, the data will use the last 24 data bits of card
 P: Parity (Even or Odd) MSB: Normal 01 LSB: Normal 24

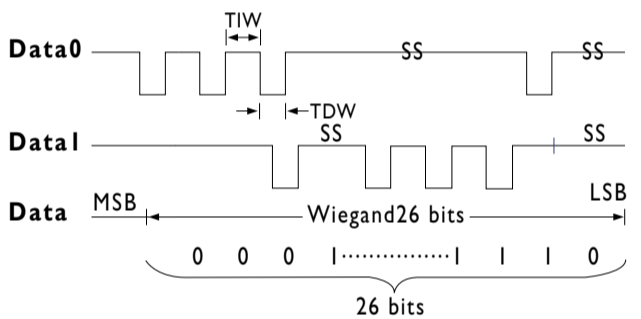

SYMBOL	Parameter	Limits Min.	Limits Max.	Type	UNITS
TDW	Data Pulse width time	20	100	48	us
TIW	Data Pulse interval time	0.2	4	2	ms
TA	Total scan time	100	-	-	ms

Number	Color	Name	Description
1	Yellow	D0	WIEGAND26 DATA0
2	Blue	D1	WIEGAND26 DATA1
3	Black	GND	Signal Ground

③ RS232

Number	Name	Description
1	NC	For wiegand26 DATA0 output
2	TXD	Transmit Data (out)
3	NC	
4	DTR	Data Terminal Ready (out), connected with DSR
5	GND	Signal Ground
6	DSR	Data Set Ready (in), connected with DTR
7	RTS	Request to Send (out), connected with CTS
8	CTS	Clear to Send (in), connected with RTS
9	NC	For wiegand26 DATA0 output

Refer the data format table:

ROW0=1	1	0	0	0	PD0=1
ROW1=2	0	1	0	0	PD1=1
ROW2=3	1	1	0	0	PD2=0
ROW3=4	0	0	1	0	PD3=1
ROW4=5	1	0	1	0	PD4=0
ROWS=6	0	1	1	0	PD5=0
ROW6=7	1	1	1	0	PD6=1
ROW7=8	0	0	0	1	PD7=1
ROW8=9	1	0	0	1	PD8=0
ROW9=A	0	1	0	1	PD9=0
PC1=1	PC1=1	PC2=0	PC3=1	0	

From the RS232 interface in the computer will get the 10 digits ASCII code are: 38 34 43 32 41 36 45 31 39 35.

5.DIMENSION:

Two levels 128mm x 138mm

